

# PROOF ROAD BLOCKER



Proof series road blocker has a solid structure as well as prominent security product about easiness at usage areas.

Cause for moving like accordion it doesn't need deep excavation for installation.

It is produced as standard length from 2 m to 5 m. Rising can be changeable between 50cm and 80 cm.

Proof series road blocker designed and produced as fully compliant for all kind of access control systems

Road blocker main structure has built from S235JR quality steels, all hydraulic parts like unit, valves, locks are from BOSCH - Rexroth brand.

## General Informations and Standards

- ▶ T-MAG control panel
- ▶ 2-3 m single piston, 4-5 m double piston
- ▶ Operation speed is 4-6 second
- ▶ 3/8 R2 Hydraulic hoses 330 bar withstand
- ▶ 100% heavy duty cycle
- ▶ Fully compliant for access control systems
- ▶ Safety photocell and support
- ▶ Wr100 desktop button
- ▶ High performance working
- ▶ Fully safe and reliable operation
- ▶ Remote control and receiver system
- ▶ 2 years warranty



## Product Details

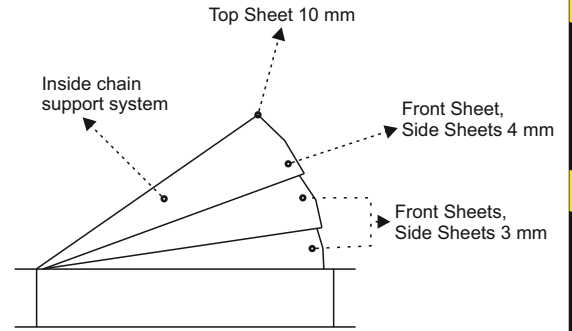
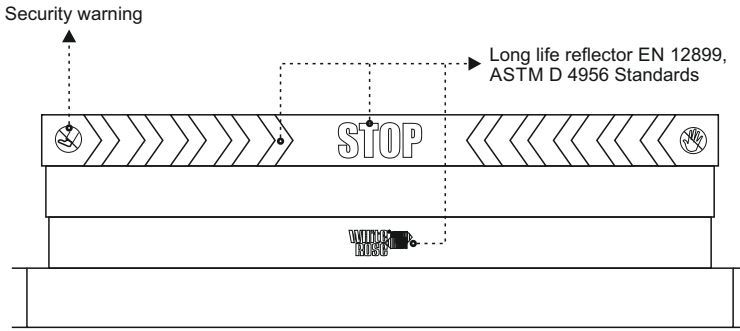

## Dimensions

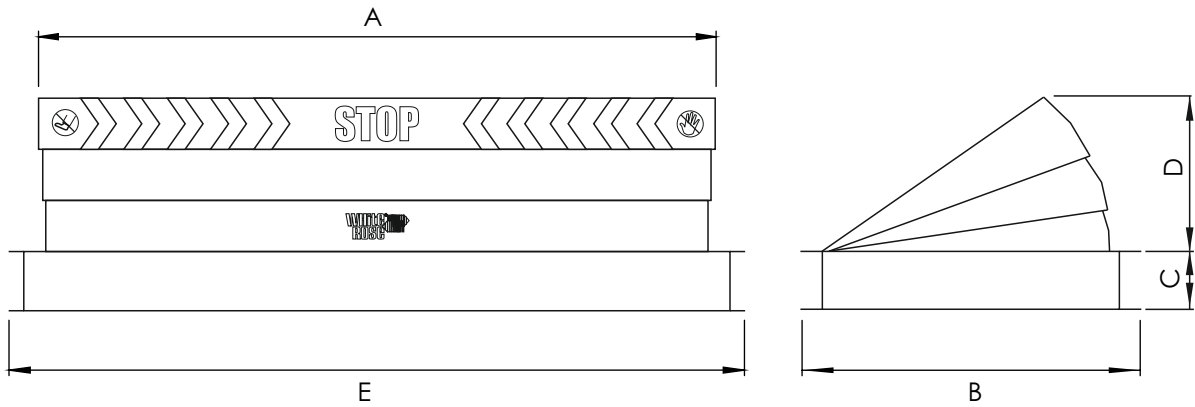

		LENGTH														
		2 M					3 M					4 M				
		A	B	C	D	E	A	B	C	D	E	A	B	C	D	E
RISING	50 cm	2000	985	210	500	2180	3000	985	210	500	3180	4000	985	210	500	4180
	60 cm		1085	210	600			1085	210	600			1085	210	600	
	70 cm		1185	210	700			1185	210	700			1185	210	700	
	80 cm		1285	210	800			1285	210	800			1285	210	800	



## Technical Datasheet

Type	PROOF SERIES			
Model	WPF200	WPF300	WPF400	WPF500
Length	2 mt	3 mt	4 mt	5 mt
Movable Part	S235JR quality steel sheet – Upper sheet 10mm / Front - Side sheets 3-4mm / Inner chain enforcements system			
Working System	Hydraulic			
Power Supply	380 V 3 Phases 50/60 Hz			
Control Card	T-MAG Control Card			
Current	3,8 A		5,15 A	
Motor Power	1,5 KW		2,2 KW	
Number of piston	Single Piston		Double Pistons	
Opening Time	4-6 sec			
Duty Cycle	100%			
Lift power	900 Kg		1800 Kg	
Limit Switch Type	Adjustable engine working period			
Working Pressure Min	20 Bar			
Working Pressure Max	75 Bar			
Manual Opening	Global valve			
Manual Closing	Optional Hand Pump			
Hydraulic Oil Type	32 or 46 number hydraulic oil			
Hydraulic Hose	3/8 R2 330 Bar			
Working Temperature	-20°C min +70°C max			
Accumulator Supply	None			
Emergency Close	Optional			

## Optional Extras

- ▶ Oil Heater
- ▶ Oil Cooler
- ▶ Emergency Fast Operation (1sec)
- ▶ Manual Hand Pump
- ▶ PLC Control Panel
- ▶ PLC Control Screen
- ▶ Traffic Lights (red-green)
- ▶ Traffic Lights post
- ▶ Loop Detector Double Contact
- ▶ Checkered non-sliding plate
- ▶ Hot-Dip Galvanization

### ADDRESS

Organize Sanayi Bölgesi  
9. Cad. No. 1 KARAMAN, TR

T: 0 338 224 13 60

F: 0 338 224 14 46

M: whiterose@whiterose.com.tr

W: www.whiterose.com.tr