

DEFENDER ROAD BLOCKER



Defender series road blocker has a solid structure as well as prominent security product about easiness at usage areas.

Cause for moving like accordion it doesn't need deep excavation for installation.

It is produced as standard length from 2 m to 4 m. Rising can be changeable between 50cm and 80 cm.

Defender series road blocker designed and produced as fully compliant for all kind of access control systems

Road blocker main structure has built from S235JR quality steels.

General Informations and Standards

- ▶ T-MAG control panel
- ▶ 2-3 m single piston, 4-5 m double piston
- ▶ Operation speed is 4-6 second
- ▶ 3/8 R2 Hydraulic hoses 330 bar withstand
- ▶ 100% heavy duty cycle
- ▶ Fully compliant for access control systems
- ▶ Safety photocell and support
- ▶ Wr100 desktop button
- ▶ High performance working
- ▶ Fully safe and reliable operation
- ▶ Remote control and receiver system
- ▶ 2 years warranty

Product Details

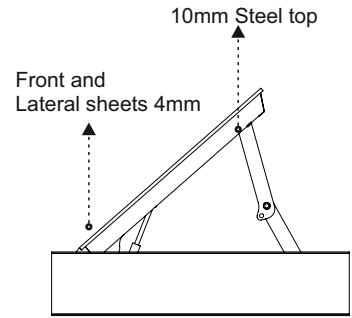
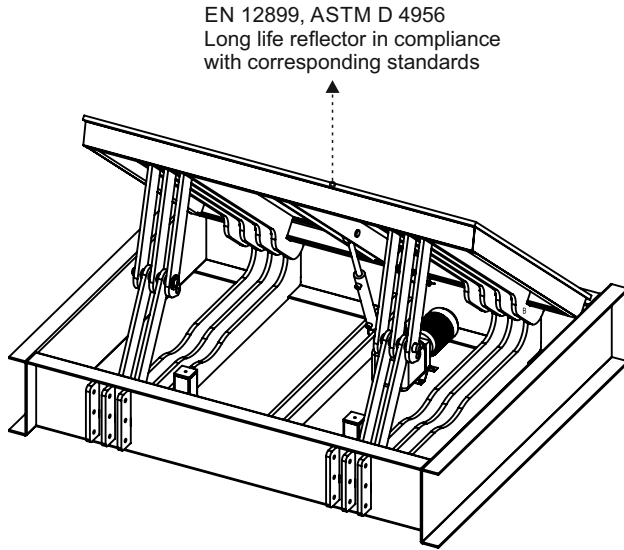

Dimensions

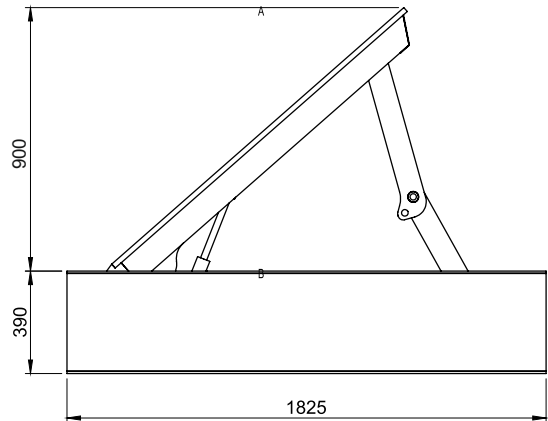
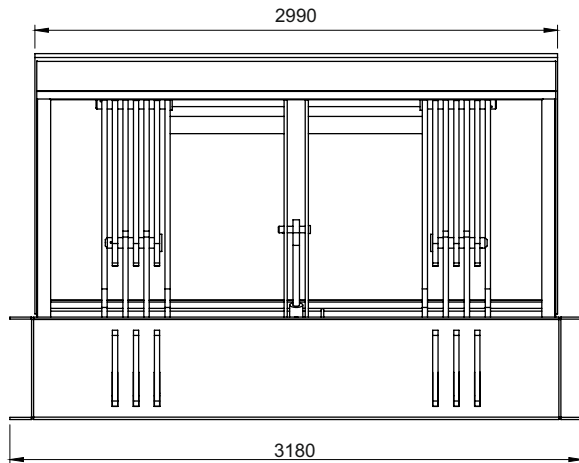



Technical Datasheet

Type	DEFENDER SERIES		
Model	WDF200	WDF300	WDF400
Length	2 mt	3 mt	4 mt
Moving part	Sheets are S235JR Quality steel - Top sheet 10mm / Front and lateral sheets 3-4mm / Internal chain		
Working system	Hydraulic		
Power source	380 V 3 Phase 50/60 Hz		
Control unit	T-MAG control unit / optional PLC		
Current draw	3,8 A		5,15 A
Motor power	1,5 KW		2,2 KW
Number of pistons	Single Piston		Double Piston
Turn on-turn off duration	4-6 second		
Continuously of operation	100%		
Lifting power	900 Kg		1800 Kg
Limit switch type	Adjustable motor operation duration		
Minimum operational pressure	20 Bar		
Maximum operational pressure	75 Bar		
Manuel opening	Through ball valve		
Manuel shutdown	Optional hand pump		
Hydraulic oil type	32 or 46 Number hydraulic oil		
Hydraulic pipe	3/8 R2 330 Bar		
Operational temperature	-20°C min +70°C max		
Accumulator support	None		
Emergency shut down	Optional		

Optional Extras

- ▶ Oil Heater
- ▶ Oil Cooler
- ▶ Emergency Fast Operation (1sec)
- ▶ Manual Hand Pump
- ▶ PLC Control Panel
- ▶ PLC Control Screen
- ▶ Traffic Lights (red-green)
- ▶ Traffic Lights post
- ▶ Loop Detector Double Contact
- ▶ Checkered non-sliding plate
- ▶ Hot-Dip Galvanization

ADDRESS

Organize Sanayi Bölgesi
9. Cad. No. 1 KARAMAN, TR

T: 0 338 224 13 60

F: 0 338 224 14 46

M: whiterose@whiterose.com.tr

W: www.whiterose.com.tr